

DISOBEDIENCE

IN THE GARDEN OF EDEN

“As by one man’s disobedience many were made sinners...

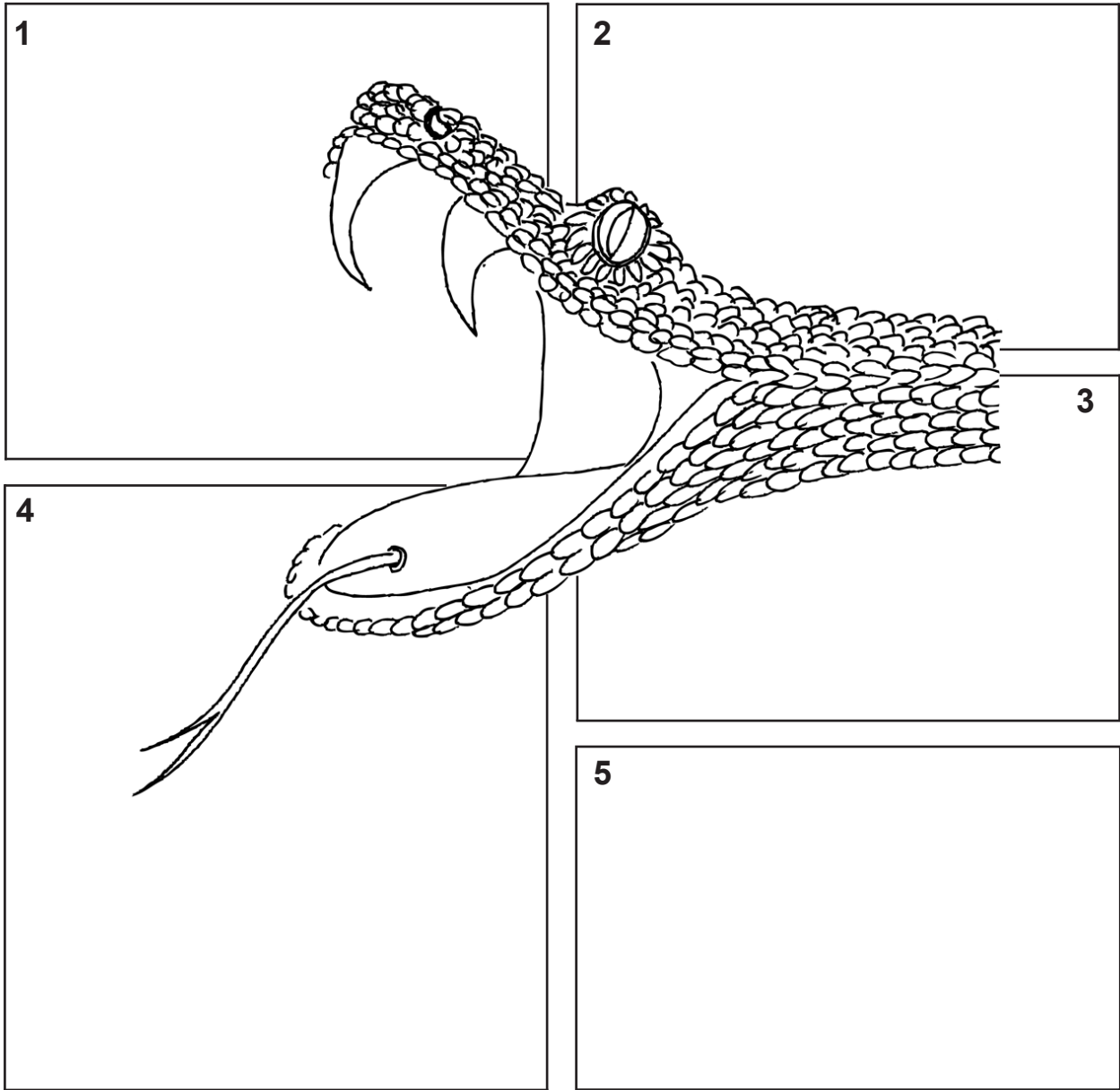

Genesis 3:15

... so by the obedience of one shall many be made righteous.”

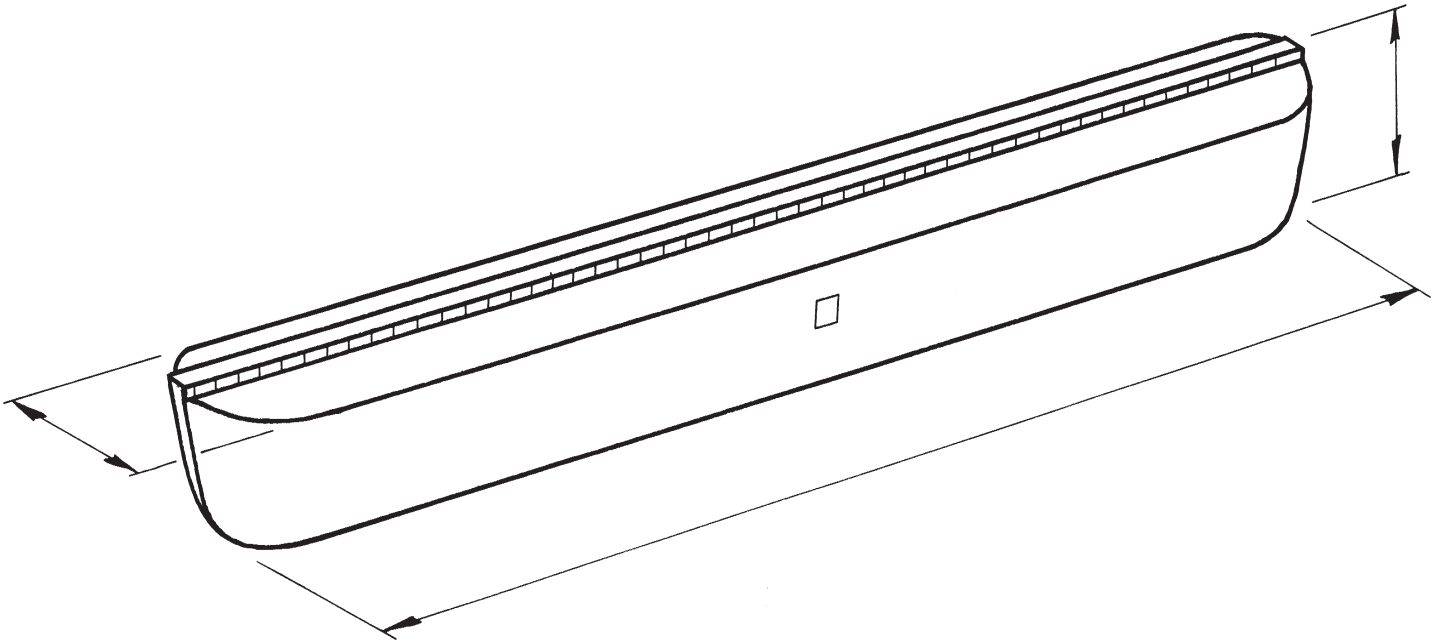

God saw the need to destroy mankind from the face of the earth because...

The provision made for Noah and his family was...

Noah was chosen to be a deliverer of his family from this destruction because...

The sign of the promise that God would not again destroy mankind in this way was...

God was going to destroy all living things from the earth by...

Jesus said concerning the days of Noah...

“By faith Noah prepared an ark to the saving of his house.”

Abraham

"A father of many nations have I made thee."

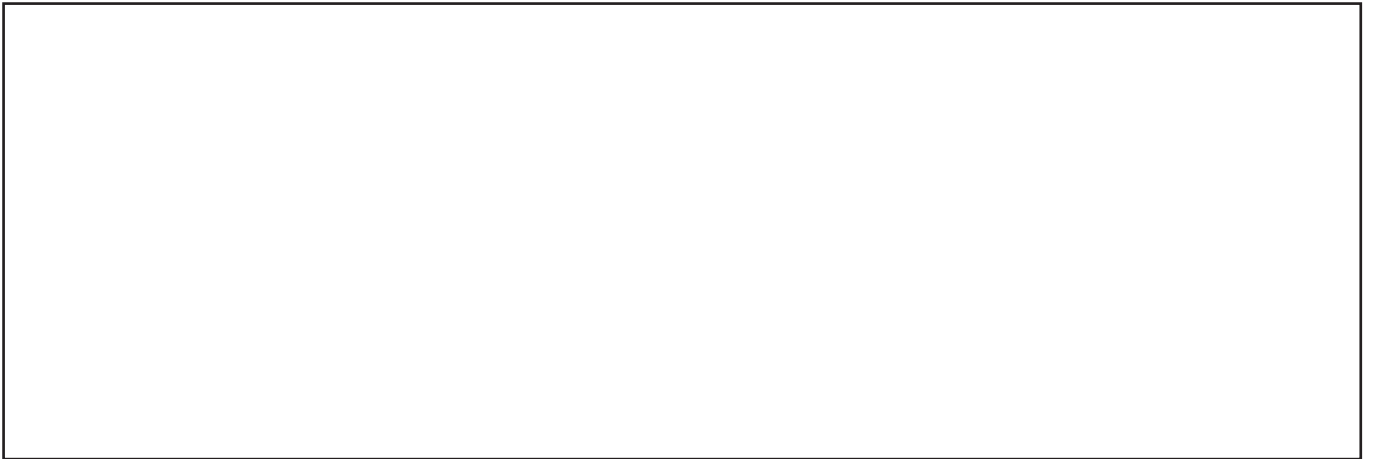
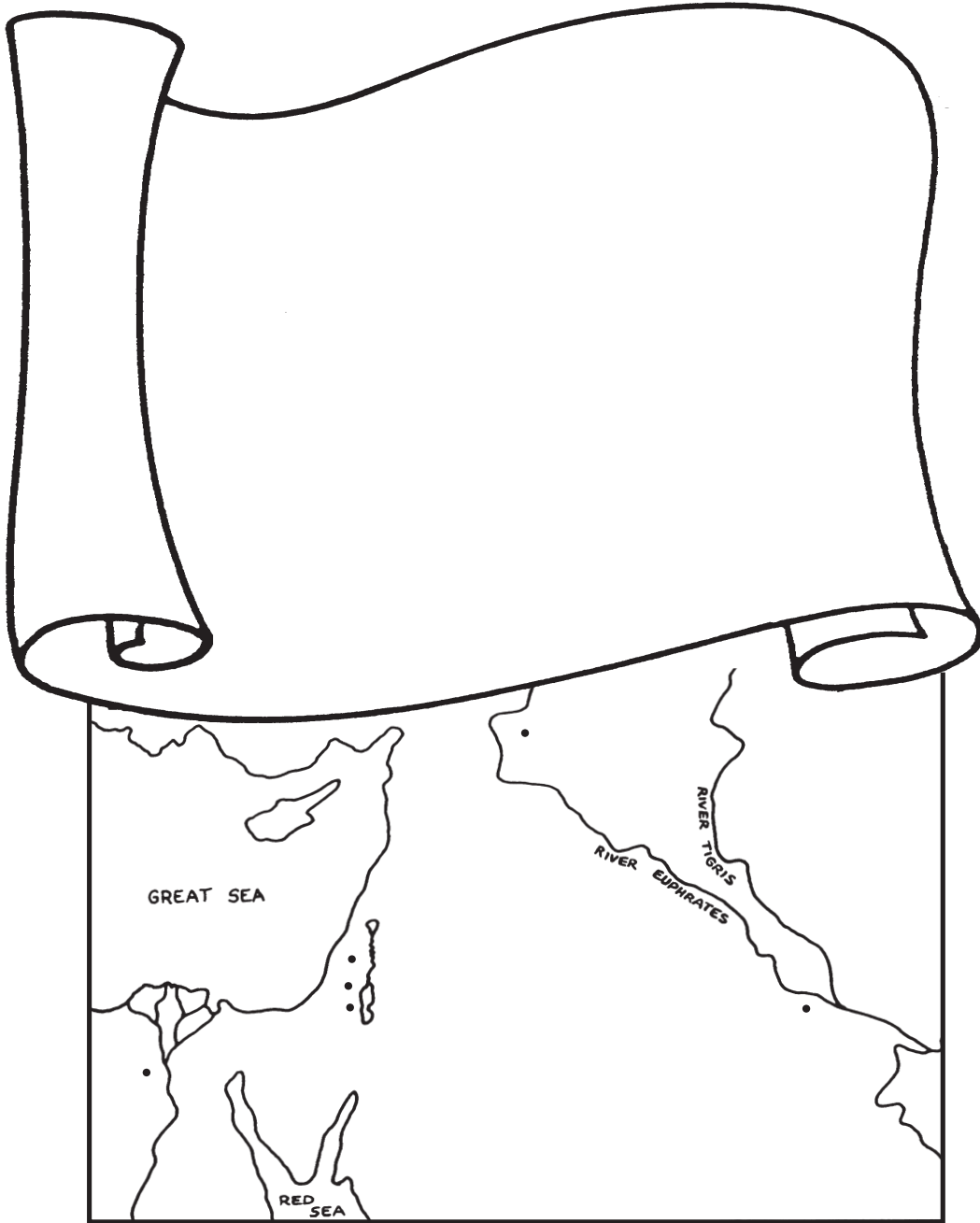

"... if ye be Christ's then are ye Abraham's seed and heirs according to the promise."

Joseph

“The Increaser”

“God sent me before you... to save your lives by a great deliverance.”

THE PASSOVER

“It is Yahweh’s Passover”

J	C	G	G	N	A	T	E	R	B	I	R	W	L	J
E	L	P	P	P	I	Y	W	Y	W	R	T	N	W	W
X	B	O	A	Z	J	G	O	U	X	Y	U	N	Z	H
G	Z	G	Z	X	W	A	T	O	D	R	O	D	M	F
K	N	H	Y	P	Q	S	C	W	U	N	I	S	I	F
W	I	I	U	P	T	B	D	A	N	H	B	R	V	X
E	C	L	N	B	A	O	U	L	N	B	S	O	N	J
Z	R	D	L	R	I	S	P	H	I	T	A	H	T	D
N	D	O	E	E	O	U	S	E	S	D	L	A	M	B
H	O	M	A	Y	D	M	O	O	I	I	U	S	X	H
D	M	T	V	S	G	H	P	X	V	R	M	T	Y	L
H	T	N	E	E	T	R	U	O	F	E	G	E	M	I
A	M	B	N	N	O	E	A	Y	X	K	R	P	L	X
Q	W	L	E	O	U	U	D	Z	P	X	S	L	R	B
W	S	T	D	G	Y	Z	S	M	Y	C	J	W	B	G

- The month Abib was to be the _____ month of Israel’s new year.
- On the _____ day they were to take a _____.
- It was to be without _____.
- It was to be kept till the _____ day of the month.
- The lamb was to be _____ in the evening.
- The _____ was to be put on the _____ of their houses.
- The lamb was to be _____, and eaten with _____ bread and bitter herbs.
- They were to eat it in _____.
- None of the lamb was to be left until _____, or it was to be burnt.
- It is the LORD’s _____.

“He smote all the firstborn in Egypt... but made His own people to go forth like sheep.”

ISRAEL IN THE WILDERNESS

“He guided them in the wilderness like a flock.”

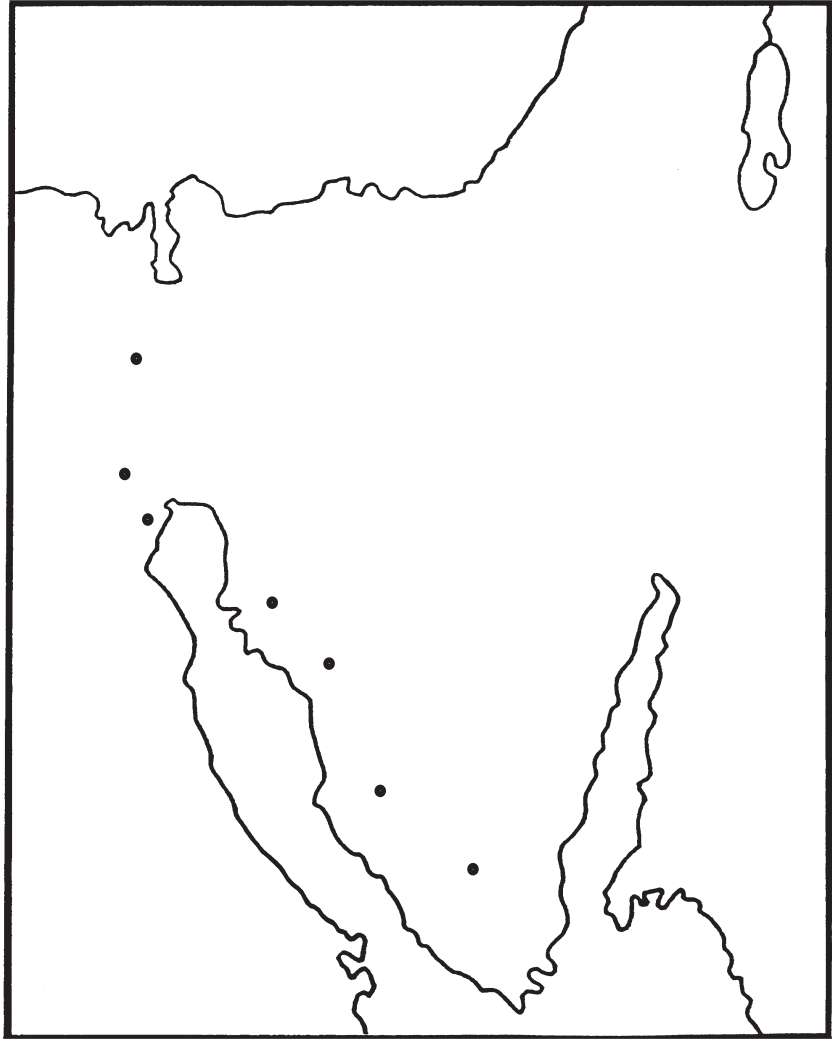

The Ten Commandments

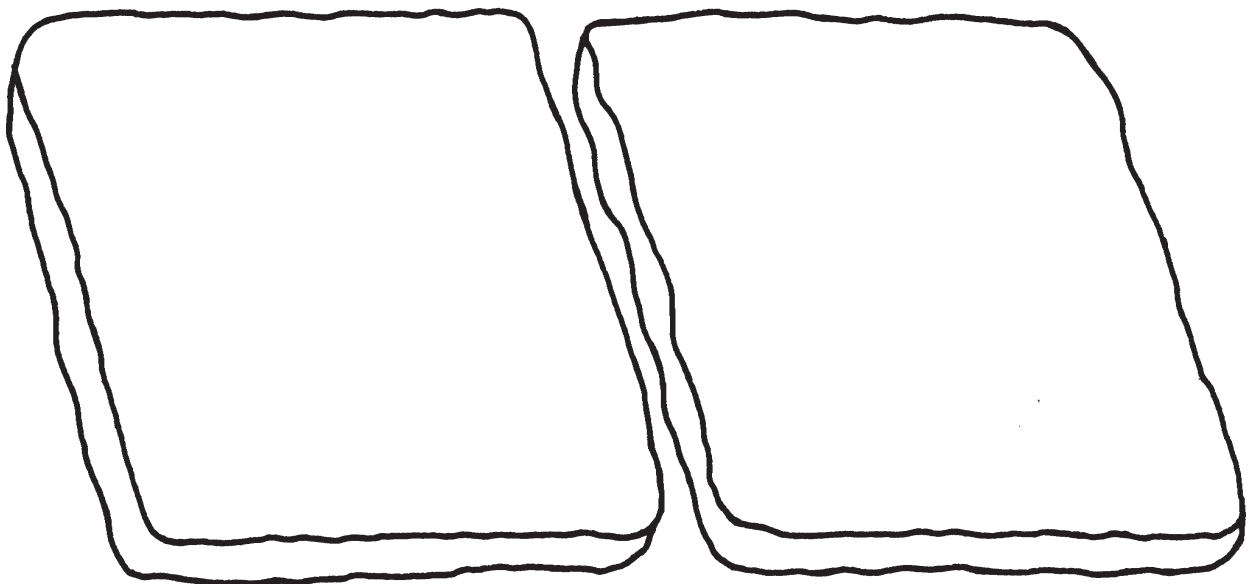

“Thou... gavest them right judgments and true laws, good statutes and commandments.”

THE TABERNACLE

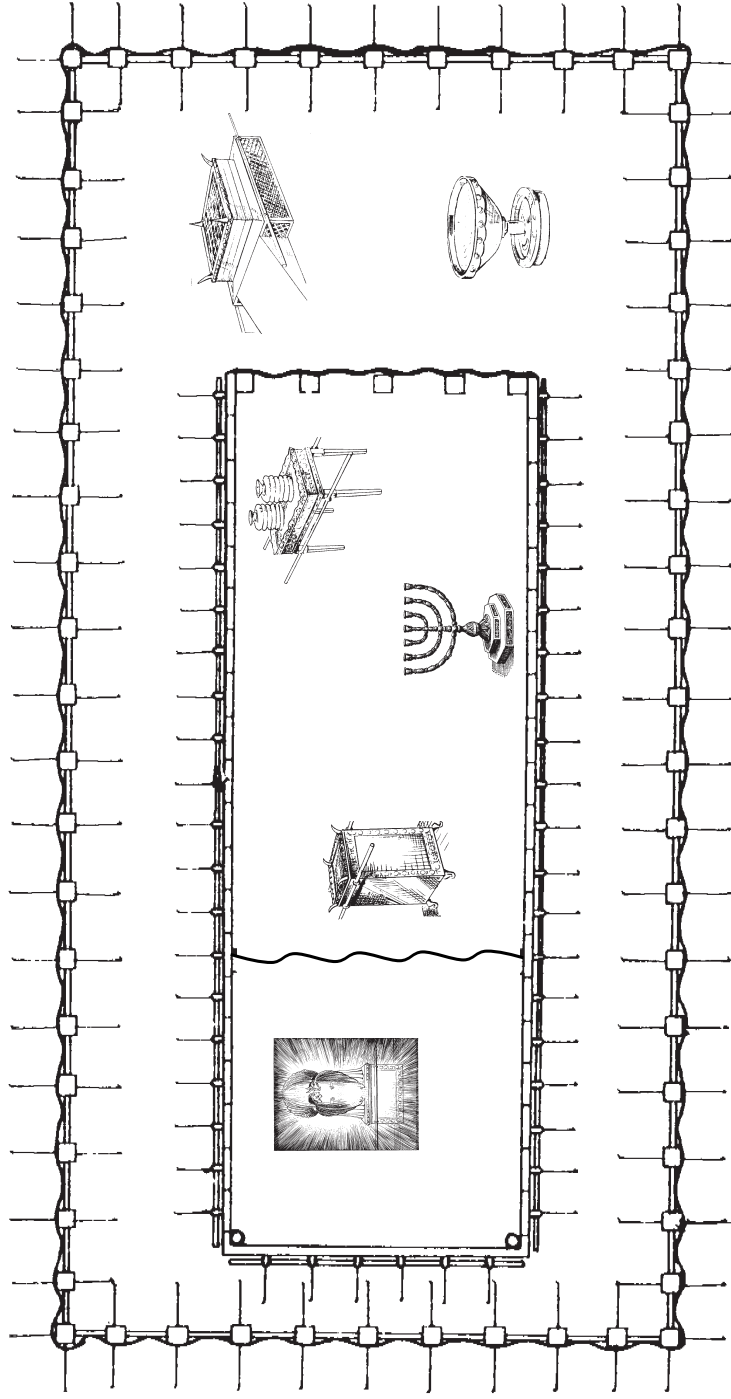

**“Let them
make me a
sanctuary,
that I may
dwell among
them.”**

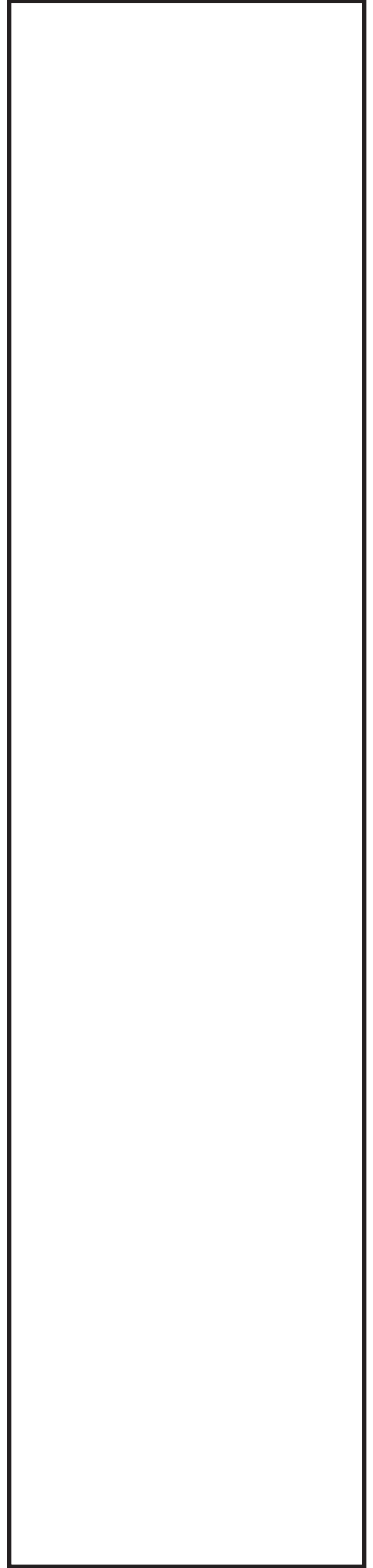

CHRISTADELPHIAN SUNDAY SCHOOL ASSOCIATION INSTRUCTIONS - JUNIOR PROJECT - DIVISION 11-12 STAGE 1 - THE PREPARATION OF THE KINGDOM

The Junior Project for Divisions 11-12 is designed to lead you toward the Intermediate Project in which you are encouraged to do some Bible marking. The project pages are in a loose leaf form to assist in working on each page. We want you to start developing the basic skills for personal Bible Study.

Some of these things are:

- The ability to write neatly in smaller print and in straight lines.
- The use of maps and colouring to highlight certain information.
- The ability to summarise concisely a scriptural subject or topic.
- The preparation of information in table form.
- The importance of providing the book, chapter and verse for a quote you may use.

While you are planning your project, keep in mind the following:

- Make sure you **follow the instructions** exactly and do all that is asked for.
- There are **no marks** given for work done on the cover.
- There are **no marks** for work on extra pages or on flaps attached to the page. **Work is not to be done on the back of the project sheets.**
- Generally, collage work is not expected on the project pages, however if you want to you may do so.

All the information requested can be found from within the Lesson Notes. You should find enclosed in the Project Folder one double sided instruction sheet and seven project pages.

On completing your project remember the following:

- Place each page in order into the Project Folder. There should be seven pages in all.
- Do not place your name on any part of your work.
- Hand in your Project Folder by the **15th JULY 2018** to your Sunday School Secretary or Superintendent.

Parents please remember:

- Your children look for and need your support and encouragement and ideas when working on their Projects, but the actual work on each page must be the child's own work.
- Please obtain and read the booklet '**GUIDELINES TO GOOD PROJECTS**'. You will also find helpful '**Stage 1 Family Bible Study Sheets**'.

INSTRUCTIONS

Page 1. Lesson 3 Disobedience in the Garden of Eden Gen 2 & 3

1. There are five statements which you are to complete, one in each of the five boxes provided. Use a quotation from Genesis chapters 2 and 3, except for statement three, where you will have to find quotes elsewhere. Your Lesson Notes are a good place to find them. Remember to include where each quotation is found. Write out the statement in the boxes provided and then complete your answer
 1. The commandment God gave to Adam and Eve was that...
 2. The serpent tempted Eve by...
 3. Sin is...
 4. God gave to Adam and Eve the covering of...
 5. After Adam and Eve sinned God drove...
2. Colour the serpent.....
3. In the space at the bottom of the page explain the meaning of Genesis 3:15 (refer to Lesson Notes page 22-23).....
4. There is a quote at the top of the page which is continued at the bottom of the page. Find where in the KJV bible this quote is from, and write it at the bottom (book, chapter and verse).....

Page 2. Lesson 5 Noah "A Preacher of Righteousness" Gen 6-8

1. Add the title to the top of the page using a rainbow and its colours.....
2. Answer the statements in the boxes with a few sentences. Use your Lesson Notes as a guide.....
3. Colour the ark and show its dimensions (see page 36 of the Lesson Notes).....
4. Below the six boxes, explain how we can enter the "Ark of Safety" (see page 39 of the Lesson Notes).....

Page 3. Lessons 6 - 7 Abraham Gen 12 & 13

1. Using the scroll provided, write out the promises given to Abram in Genesis 12:2-3.....
2. Colour the map of ancient Mesopotamia and the Land of Promise and show the journeys of Abraham from Ur of the Chaldees into the Land of Canaan. Label the following places: Ur, Haran, Shechem, Bethel, Egypt and Hebron.....
3. In Genesis 13:3-10, Abram and Lot decide to part ways. At the bottom of the page describe what land Lot chose and why, and what land Abram chose and why. You can show this by writing in your own words or in illustration form.....

Page 4. Lessons 12 - 14 Joseph Gen 37 - 47

1. Prepare a table of the events in Joseph's life which are typical of the life of the Lord Jesus Christ. There are at least twelve listed on pages 83,84 and 96 of your Lesson Notes.....
2. At the bottom of the page illustrate any two incidents from the life of Joseph. You may like to use a comic strip style

Page 5. Lesson 18 The Passover Ex 12

1. Use Exodus 12:1-14 (KJV) to fill in the words missing from the sentences on the right of the page. These thirteen words are also hidden in the find-a-word. Find and colour the words, remembering that they may be placed in any direction.....
2. Below this, in the box provided, explain the events of Israel's crossing of the Red Sea and what it is typical of (refer to the Lesson Notes page 128).....

Page 6. Lessons 18 - 20 Israel in the Wilderness Ex 13 - 20

1. Colour the map of Egypt and the Sinai Peninsula showing the journeys of Israel to Mt Sinai.....
2. Write the names of the places they went through and on the left side in a few words describe what happened in each place....
3. Record the Ten Commandments in the outline of the tables of stone

Page 7. Lessons 22 - 23 The Tabernacle Ex 25 - 39

1. Label the rooms, furniture and dimensions of the tabernacle on the picture provided. Use the information given in Lessons 22 and 23.....
2. In the box provided give a brief description of the six items of furniture and the lessons they teach in worshipping God.....
3. Around the outside of the page, as a border, write the names of the 12 Tribes of Israel in their marching order. This can be found on page 154 of your lesson notes.....

Use the check boxes to ensure you have done all that is asked